

User Manual M5-1C/2C/3C-86W(EN)



SwitchMan Smart Wall Switch

User Manual V1.0

Introduction

This device is a smart physical wall switch. After pairing it with eWeLink App, you can turn on/off the connected devices via the smart phone wherever you are, schedule its on/off, share it with your families to control together, etc.



Remote Control



Single/Countdown
Timing



Voice Control



Share Control



Smart Scene



Inching Mode



Camera Linking



Group Control



History Operation
Record



LAN Control

① Button

- Press once: Turn on/off the Device.
- Press and hold for 5 seconds : Device enters the pairing mode.

② Wi-Fi LED indicator (Blue)

eWeLink Mode

- Keeps on: Device is online.
- Flashes twice: LAN
- Flashes once: Offline
- Flashes two short and one long: Device is in pairing mode.

Matter Mode

- Keeps on: Device is online.
- Flashes once: Offline
- Flashes two short and one long: Device is in pairing mode.
- Flashes three times: Identify

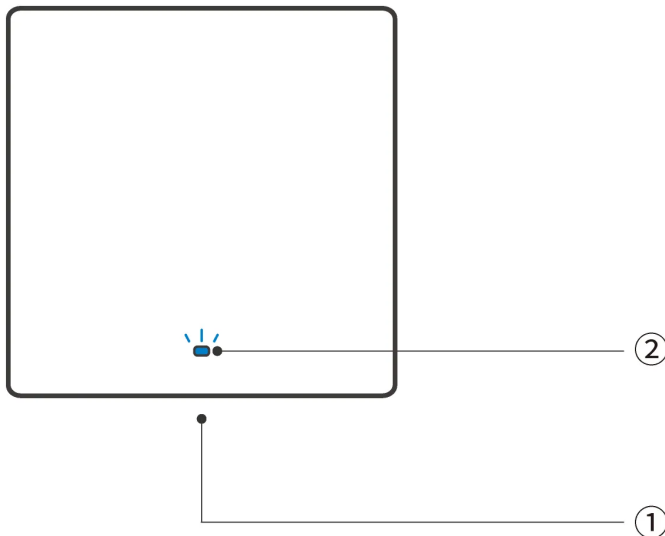

Matter-compatible ecosystem



Specification

| | |
|-----------------------|---|
| Model | M5-1C-86W, M5-2C-86W, M5-3C-86W |
| MCU | ESP32 |
| Rating | 1C: 100-240V ~ 50/60Hz 10A Max 2C: 100-240V ~ 50/60Hz 5A/Gang 10A Total Max 3C: 100-240V ~ 50/60Hz 2A/Gang 6A Total Max |
| Max. load | 1C: 2200W 2C: 2200W(1-1100W/Gang) 3C: 1320W(1-440W/Gang) |
| LED load | 1C: 300W/220V, 150W/110V 2C: 300W/220V/Gang, 150W/110V/Gang 3C: 100W/220V/Gang, 60W/110V/Gang |
| Wireless Connectivity | IEEE 802.11 b/g/n 2.4GHz |
| Net Weight | 1C(153.8g) 、 2C(160g) 、 3C(163.7g) |
| Dimension | 86x86x41.5mm |
| Color | White |
| Casing Material | PC V0+CRS |
| Applicable Place | Indoor |
| Working Temperature | -10°C~40°C |
| Working Humidity | 5%~95% RH, non-condensing |
| Certified Compliance | CE/CQC/RoHS |
| Executive standard | EN 60669-2-1 |

Installation

1. Power off

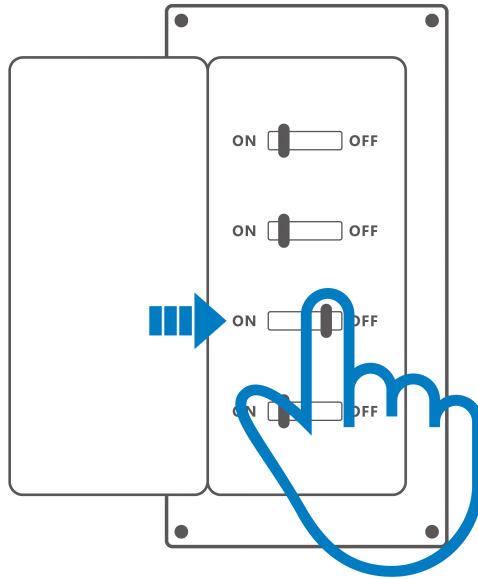

**Please install and maintain the device by a professional electrician. To avoid electric shock hazard, do not operate any connection or contact the terminal connector while the device is powered on!*

2. Wiring instruction

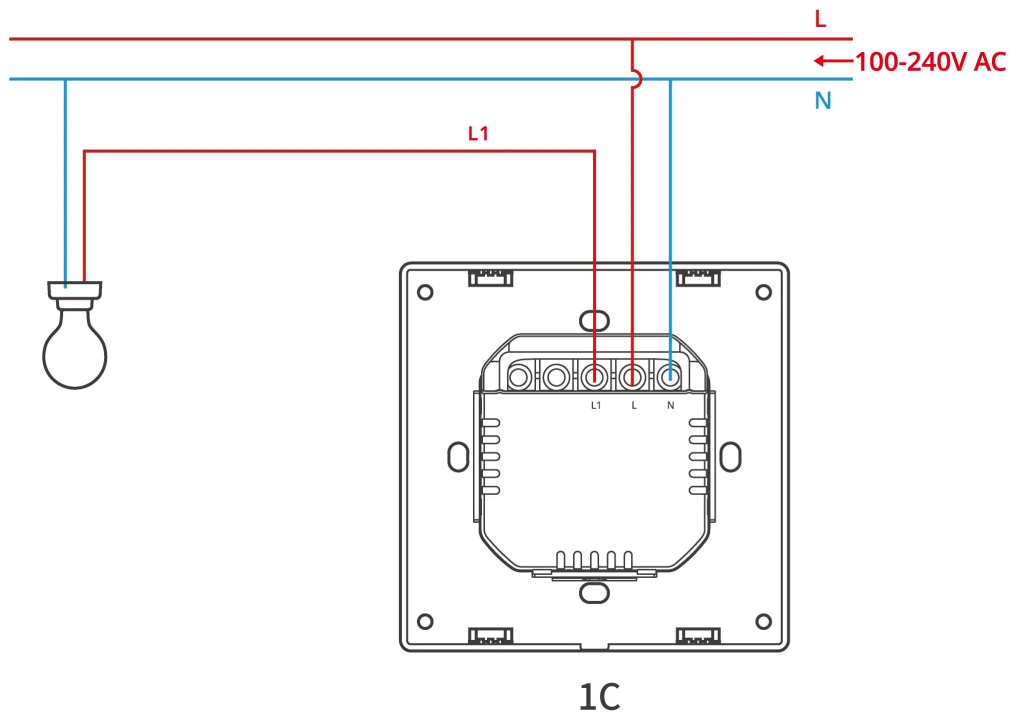

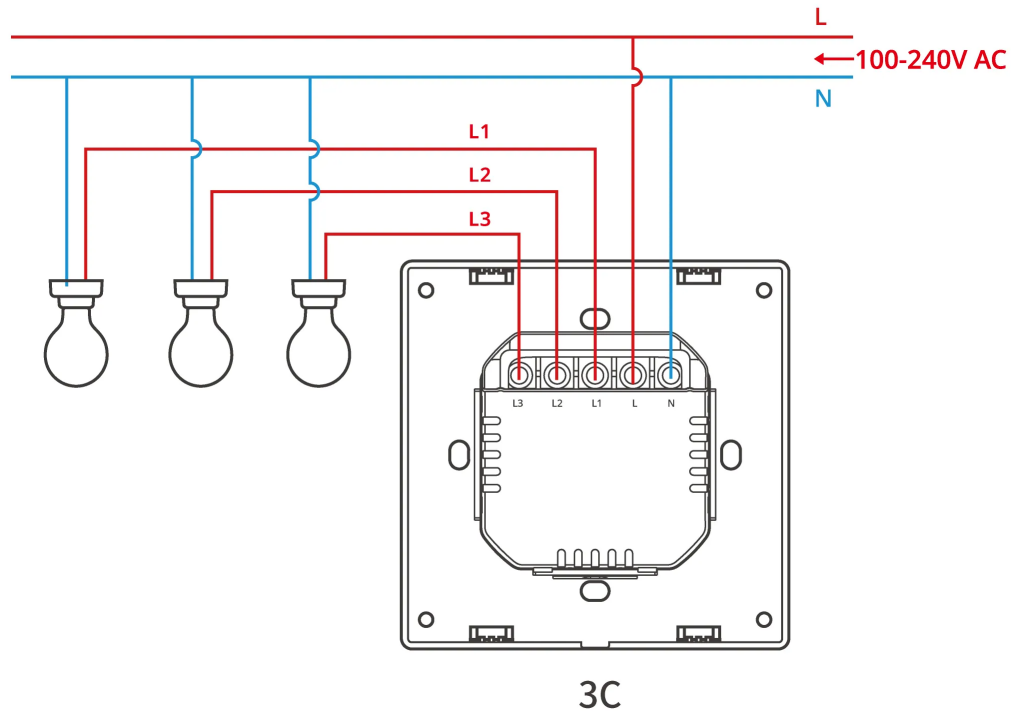
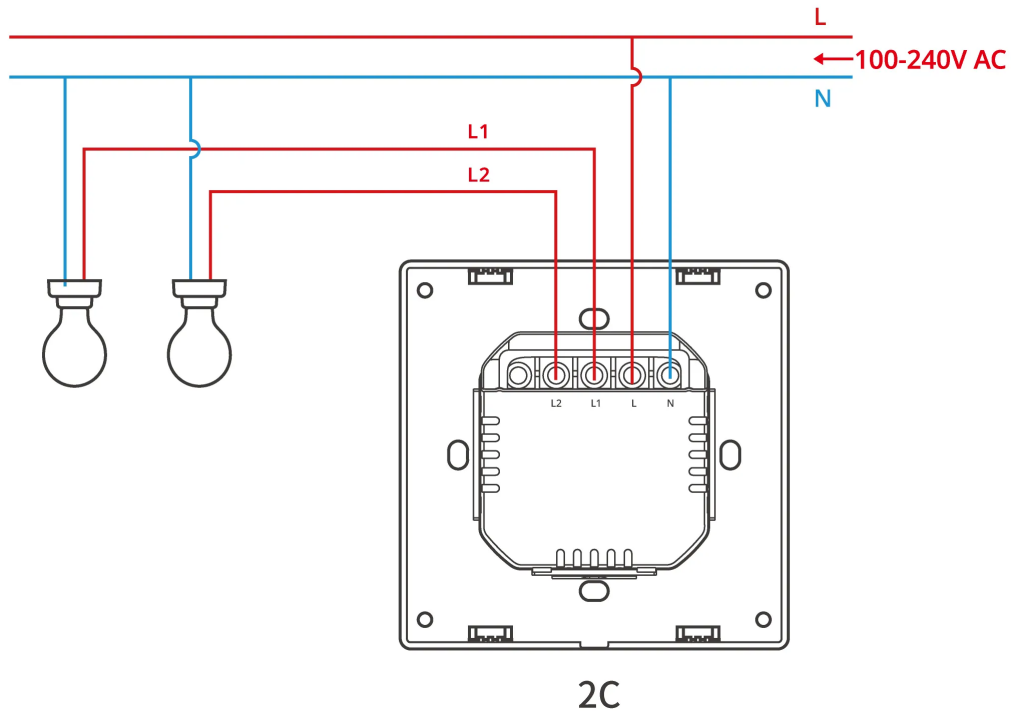

*To ensure the safety of your electrical installation, it's essential either a Miniature Circuit Breaker (MCB) or a Residual Current Operated Circuit Breaker (RCBO) with an electrical rating of 10A (1C,2C),6A (3C)has been installed before the M5-86W.

*Make sure all wires are connected correctly.

3. Power on

After powering on, the device will enter the Pairing Mode defaulted during the first use, and the LED indicator flashes in a cycle of two short and one long.

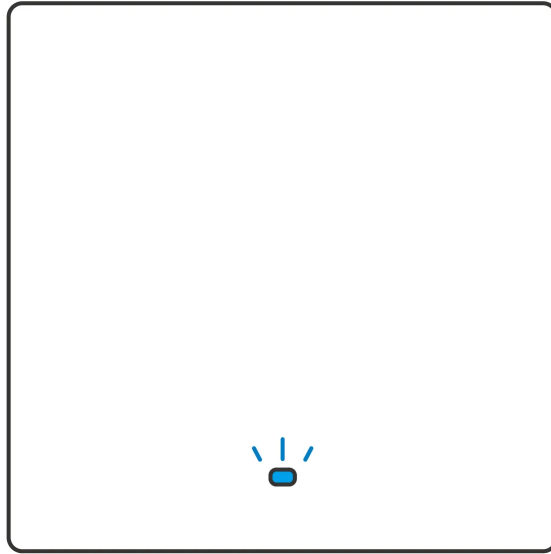

*The device will exit the Pairing Mode if it is not paired within 10mins. If you want to enter this mode again, please long press the button for 5s until the LED indicator flashes in a cycle of two short and one long and then release.

Add device

Method 1: Matter Pairing

Open a Matter-compatible App (e.g. Alexa App, Google Home App, or Apple Home App, etc) to scan the Matter QR code on the Quick Guide or the device itself to add the device.



Add to Alexa via Matter



Add to Google via Matter

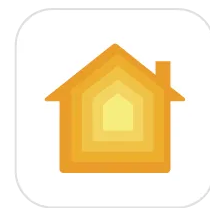

Add to Apple via Matter

Method 2: eWeLink App Pairing

1. Download the "eWeLink" App

Please download the "eWeLink" App from Google Play Store or Apple App Store.

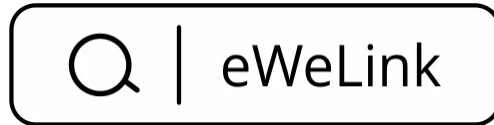

2. Add device

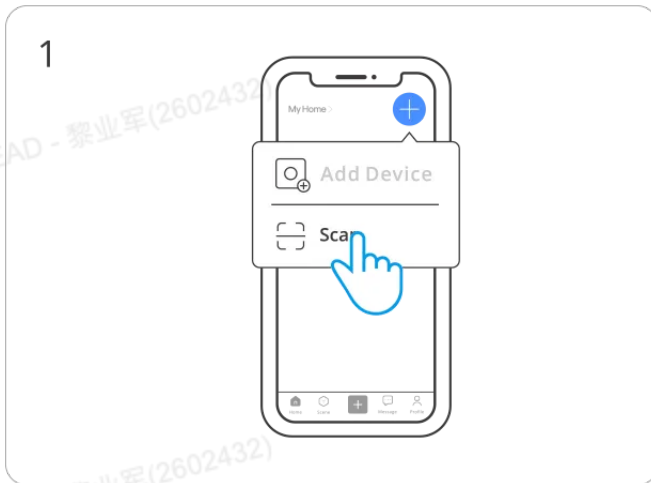

Enter "Scan"

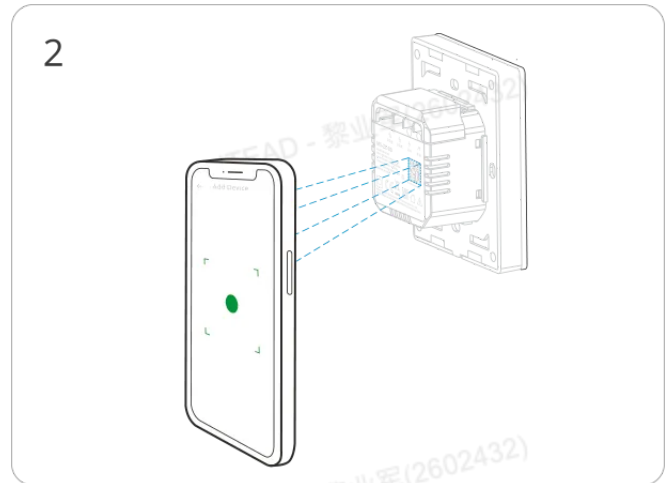

Scan the QR code on the device

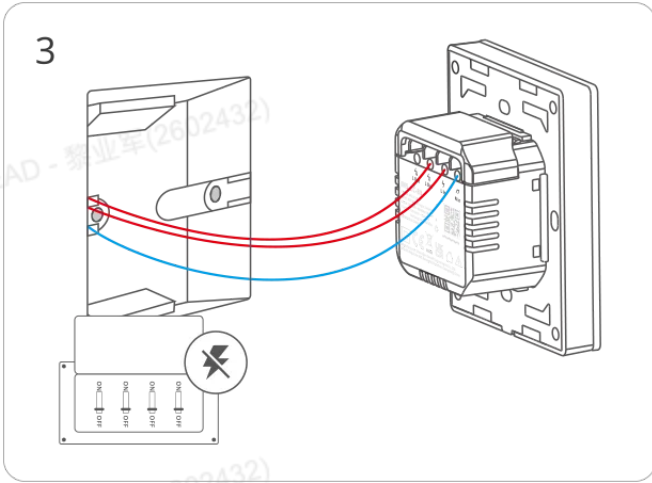

Please follow the wiring instructions to connect the wires (ensure power is disconnected in advance and consult an electrician if needed)

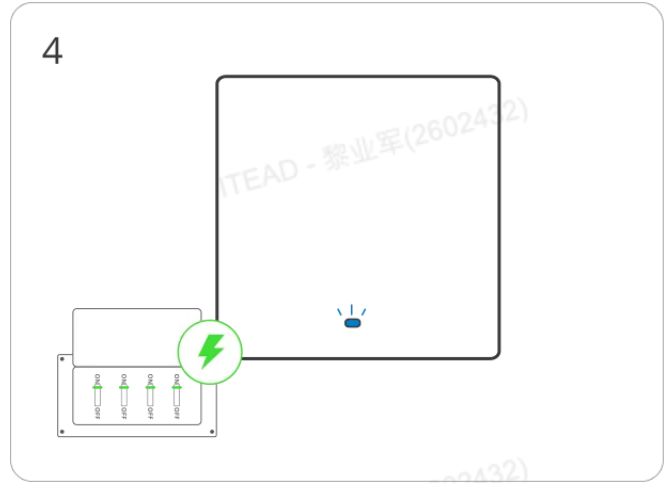

Power on the device

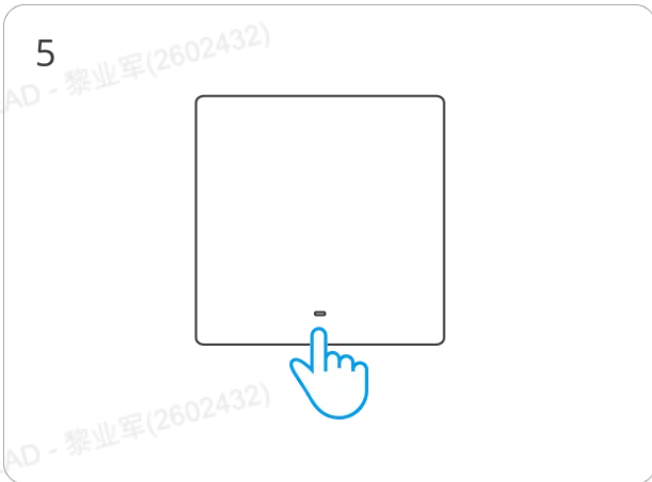

Long press the button for 5 seconds

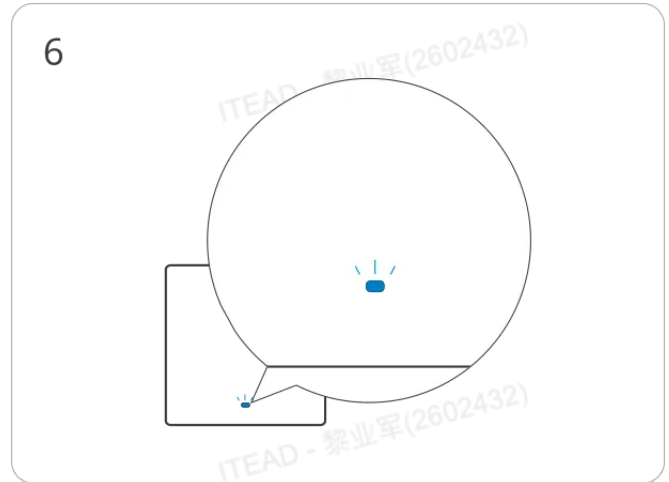

Check Wi-Fi LED indicator flashing status
(Two short and one long)



Select "Add Device"



Search for the device and start connecting

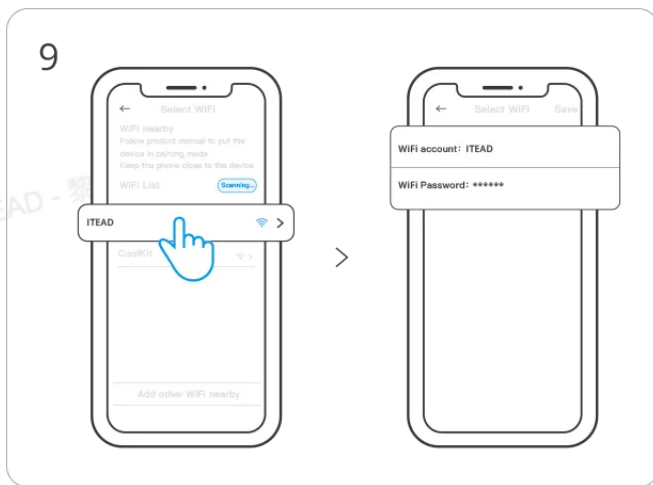

Select the "Wi-Fi" network and enter the password.

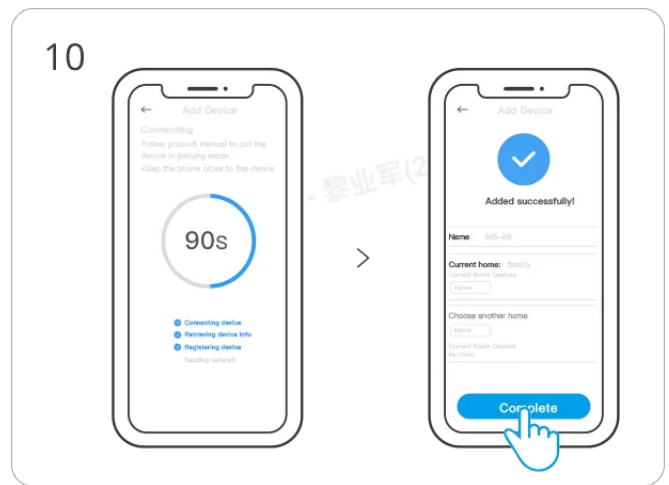

Device "Added completely".

Device Network Changing

Change the device's network by "Wi-Fi Settings" in the "Device Settings" page on the eWeLink App.

Device Factory Reset (Dual Ecosystem)

- After "Delete the Device" in the eWeLink App
- For devices previously successfully added to eWeLink, perform a new pairing using a different eWeLink account

- For devices previously successfully added in Matter, perform a new Bluetooth Pairing through Matter

FAQ

Fail to pair Wi-Fi devices with eWeLink APP

1. Make sure the device is in pairing mode.

The device will automatically exit the pairing mode if not paired within 10mins.

2. Please turn on the location service on your mobile phone and give the permission.

Before choosing the Wi-Fi network, the location service should be turned on and the permission is given. Location information permission is used to obtain Wi-Fi list information. If you tap "Disable", the device will not be added.

3. Make sure your Wi-Fi network runs on the 2.4GHz band.

4. Make sure you entered a correct Wi-Fi SSID and password, no special characters contained. A wrong password is a very common reason for pairing failure.

5. You may get the device close to the router for a good signal transmission while pairing.

6. Please try to pair the device in the compatible mode.

Wi-Fi devices "Offline" issues

Please check the following issues by the Wi-Fi LED indicator status:

The LED indicator blinks once every 2s means you fail to connect to the router.

1. Maybe you entered a wrong Wi-Fi SSID and password.

2. Make sure your Wi-Fi SSID and password don't contain special characters, for example, the Hebrew, Arabic characters. Our system can't recognize these characters so that fail to connect to the Wi-Fi.

3. Maybe your router has a lower carrying capacity.

4. Maybe the Wi-Fi signal strength is weak. Your router is too far away from your device, or there may be some obstacles between the router and the device so that the signal transmission is blocked.

5. Be sure that the MAC of the device is not on the blacklist of your MAC management.

The LED indicator flashes twice on repeated means you fail to connect to the server.

1. Make sure the Internet connection is normal. You can use your phone or PC to connect to the Internet, and if you fail to access, please check the availability of the Internet connection.
2. Maybe your router has a low carrying capacity. The number of devices connected to the router exceeds its maximum value. Please check the maximum number of devices that your router can carry. If the number of connected devices exceeds the maximum value, please delete some devices or change a larger router and try again.
3. Please contact your ISP and confirm our server address is not shielded:

cn-disp.coolkit.cc (China Mainland)

as-disp.coolkit.cc (in Asia except China)

eu-disp.coolkit.cc (in EU)

us-disp.coolkit.cc (in US)

If none of the above methods solved this problem, please submit your issue via help&feedback on the eWeLink App.

SAR Warning

Under normal use of condition, this equipment should be kept a separation distance of at least 20 cm between the antenna and the body of the user.

Dans des conditions normales d'utilisation, cet équipement doit être maintenu à une distance d'au moins 20 cm entre l'antenne et le corps de l'utilisateur.

WEEE Warning



WEEE Disposal and Recycling Information All products bearing this symbol are waste electrical and electronic equipment (WEEE as in directive 2012/19/EU) which should not be mixed with unsorted household waste. Instead, you should protect human health and the environment by handing over your waste equipment to a designated collection point for the recycling of waste electrical and electronic equipment, appointed by the government or local authorities. Correct disposal and recycling will help prevent potential negative consequences to the environment and human health. Please contact the installer or local authorities for more information about the location as well as terms and conditions of such collection points.

EU Declaration of Conformity

Hereby, Shenzhen Sonoff Technologies Co., Ltd declares that the radio equipment type [M5-1C-86W, M5-2C-86W, M5-3C-86W] is in compliance with Directive 2014/53/EU. The full text of the EU declaration of conformity is available at the following internet address:

<https://sonoff.tech/compliance/>

| Scatola | Scatola | Manuale | Borsa | Borsa |
|---|---------|---------|----------|----------|
| PAP 20 | PAP 21 | PAP 22 | CPE 7 | LDPE 4 |
| Carta | Carta | Carta | Plastica | Plastica |
| RACCOLTA DIFFERENZIATA | | | | |
| Verifica le disposizioni del tuo Comune. Separa le componenti e conferiscile in modo corretto. | | | | |



Manufacturer: Shenzhen Sonoff Technologies Co., Ltd.

Address: 3F & 6F, Bldg A, No. 663, Bulong Rd, Shenzhen, Guangdong, China

ZIP code: 518000

Service email: support@itead.cc

Website: sonoff.tech

Made in China

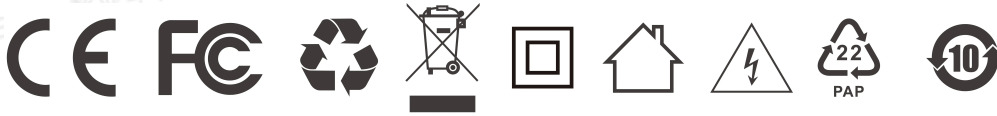

Points de collecte sur www.quefairedemesdechets.fr
Privilégiez la réparation ou le don de votre appareil !